

# 2R100SD

Broyeur déchiqueteur  
Industriel

Industrial shredders



**2 arbres / Entraînement hydraulique**

2 shaft / Hydraulic drive

**75 kW**

**ISIGRANTech**  
Partenaire intégrateur pour la France

**SatrindTech**  
Shredding Solutions

# 2R100SD

Made in Italy 

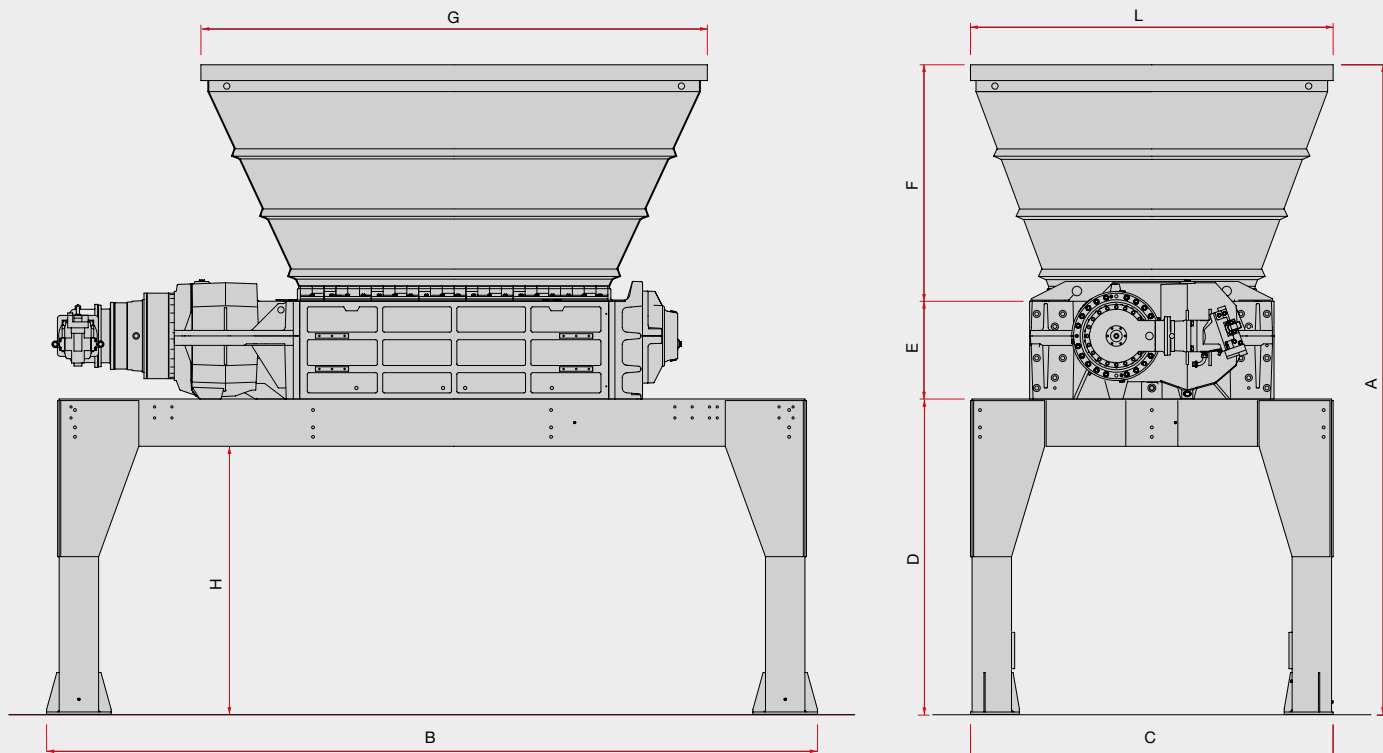





## Dimensions - Dimensions

Modèle Model	A mm	B mm	C mm	D mm	E mm	F mm	G mm	H mm	L mm
2R15/100SD	4120	4440	2300	2000	620	1500	2760	1700	2300
2R20/100SD	4120	4890	2300	2000	620	1500	3210	1700	2300

## Données techniques - Technical data

Modèle Model	Chambre de broyage Shredding chamber	Epaisseur des lames Blades thickness	Puissance Power	Poids Weight
2R15/100SD	1510x1100 mm	50 - 75 mm	75 kW	12900+1620 kg
2R20/100SD	1960x1100 mm	50 - 75 mm	75 kW	14850+1620 kg

## Applications - Applications

	<b>Déchets industriels</b> Industrial scraps/waste	5-7
	<b>Pneus</b> Tyres	4-6
	<b>Déchets urbains solides</b> Municipal solid waste	8-15
	<b>Tambours métalliques</b> Metal drums	90-140 pcs/h
	<b>Déchets encombrants</b> Bulky waste	2-4
<b>Matériaux - Material</b>		<b>t/h</b>